



*Harbour*  
INDUSTRIES  
*High Performance Wire & Cable*

## **Shielding Effectiveness Test Method**

**Harbour's LL, SB, and SS Coaxial Cables**

**Designs for Improved Shielding Effectiveness**

Harbour Industries has been manufacturing strip braided expanded PTFE dielectric coaxial cable (LL series) and strip braided solid PTFE dielectric coaxial cable (SB series) since 1988. The strip braid design is a proven, effective shield configuration. Flat strips of silver plated copper are braided over the dielectric, then an intermediate aluminum mylar or aluminum kapton tape is applied under a silver plated copper round wire braid.

### ***The need for improved shielding effectiveness***

High frequency cable and assemblies have been used in environments requiring a high level of shielding such as commercial and military aviation, defense systems, antenna systems and microwave test leads. Today, cellular and personal communication systems require cable and assemblies with the same high level of shielding. Cables must provide adequate isolation to preserve the integrity of the system and to avoid interference with over-the-air communications.

Harbour supplies cable assembly houses with reliable high performance cable. Test data must be given, including impedance, attenuation, structural return loss, and shielding effectiveness. Since the strip braid composite configuration had previously been used and published data existed, there seemed to be little need for testing cables for shield effectiveness. Later, however, it was discovered that many cable manufacturers made general statements about shielding, but did not perform shielding effectiveness tests, certainly not at frequencies above 1 GHz. At best, one RF leakage number was given for a given shield configuration. Test procedures were difficult to obtain.

### ***A new, improved shield configuration***

In 1993, Harbour designed a new SS series of high frequency coaxial cables with a new shield design of silver plated copper strip spiraled around a solid PTFE dielectric. Since these cables were frequently used as flexible alternatives for semi-rigid coax, it was time to develop a reliable, repeatable test procedure for shielding effectiveness. RF leakage and transfer impedance were considered in developing a test method. Other methods, such as open field antenna sites, absorbing clamps, and TEM cells were deemed less reliable in comparing one cable to another.

### ***Shielding effectiveness (RF leakage and transfer impedance)***

Radiation, or the transformation of energy out of a coaxial cable, is known as RF leakage. The formula for RF leakage is as follows:

$$\text{dB} = 10 \log_{10} \frac{P_t}{P_i}$$

RF leakage, measured in decibels (dB), compares the input power level ( $P_i$ ) to the power level propagating in the test chamber ( $P_t$ ). The power in the test chamber is a function of the chamber itself and the attenuation, impedance and velocity of propagation of the cable under test. Importantly, the ability of the shield to attenuate the energy passing through it enables comparison of various shield configurations. The transfer impedance of a coaxial cable is defined as the ratio of the voltage in the disturbed circuit to the current flowing in the interfering circuit. The current on one surface of the shield is related to the voltage drop generated by this current on the opposite surface of the shield. This value depends solely on the shield construction.

**Test setup**

Shielding effectiveness testing was performed to evaluate the relative ratings of different cables. Testing was performed in accordance with MIL-T-81490, with actual measured values difficult to substantiate. Repeatability was questionable. Therefore, the following triaxial test assembly was constructed in accordance with MIL-C-39012C for RF leakage.

Figure 1: Triaxial test assembly

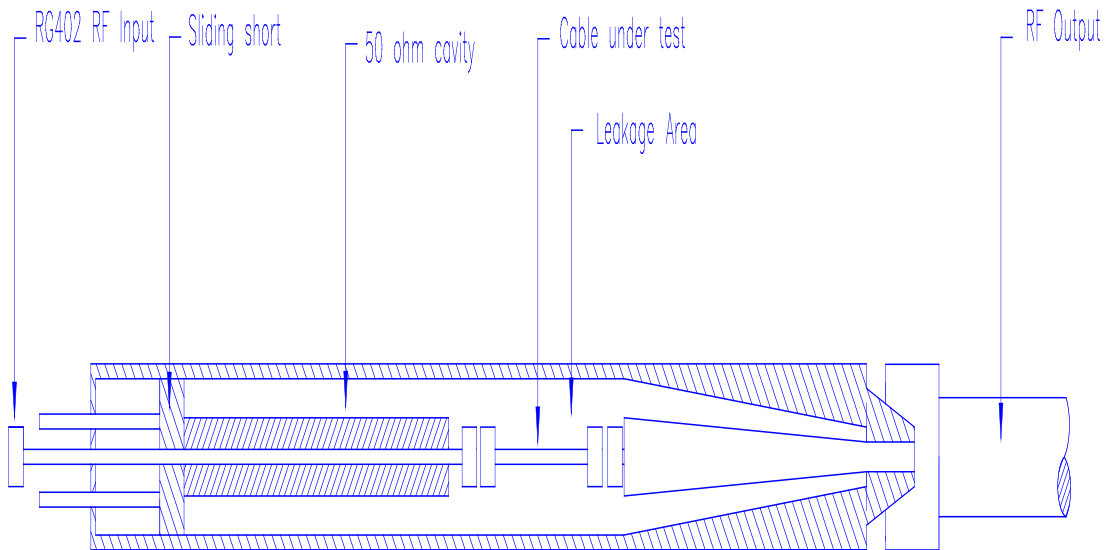

A Hewlett Packard Network Analyzer was calibrated and used with the triaxial test assembly as shown in Figure 2. To differentiate cable leakage from connector leakage, 4 and 8 inch test cables were used. For connector leakage, a test sample of 8 inches versus 4 inches will not increase the measured leakage. For a cable leakage, the longer sample will increase the measured leakage by +6 dB. Therefore, if the longer cable causes a 6 dB change in measured leakage, it can be deduced that the leakage is coming from the cable and not the connector or connector/cable interface.

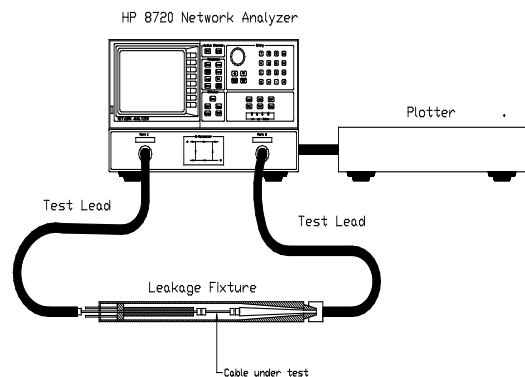

Figure 2: Shielding effectiveness test setup

The following shielding effective test procedure was developed:

- \*Connect a semi-rigid calibration cable within the leakage cell into the internal matched termination.

- \*Solder all connections for calibration to eliminate any leakage.

- \*Connect the input side of the leakage cell to port one of the analyzer and connect the output side of the leakage cell to the analyzer with the other test cable. (The calibration measurement of the system must meet the device under test levels by at least -6 dB. For Harbour's setup, the specification was -90 dB prior to testing, with a calibration reading of - 96 dB minimum required prior to testing.)

- \*Measure the insertion loss over the band of the sweep.

- \*Once the required value is met for calibration, store the data to memory in the analyzer.

- \*Disconnect the calibration samples within the cell.

- \*Move the coaxial cable out of the cell, and insert the test sample between the calibration cable connection just separated.

- \*Reconnect the test cell and re-measure the insertion loss. Adjust connections to eliminate false leakage signals from inhibiting the measurement. (Use aluminum foil to prevent connector leakage.)

- \*Slide the short circuit rod within the leakage cell back and forth to cover at least one half wavelength of travel at the test frequency. (This is to phase tune the leakage signals with the output connector, maximizing the signal at any variable phase.)

Note that the sliding of the variable short circuit is not required when making swept frequency measurements since phase tuning will be accomplished over the band. The sliding short circuit is used for a fixed, single frequency measurement test to ensure there is not a null resonance within the cavity.)

- \*Once a proper measurement has been reached, and the measured leakage signal resembles that of the test cable, plot the result and store it to a disk file, similar to all other microwave test measurements. (This plot has the stored memory trace of the fixture calibration and the test cable. The intent is to notice the measurement noise level, relative to the leakage from the test cable.)

- \*Disconnect the leakage cell, reconnect the calibration test cables within the cell to make sure the noise floor is still within the required levels given above.

Typically, leakage measurements over frequency can have two responses. If there is a physical gap or leak, the leakage response will show more leakage as frequency is increased. If there is a conductive, or absorptive path for leakage, the low frequency leakage may appear higher, since this path is shorter at lower frequencies and attenuating the signal more at higher frequencies. Any leakage due to a cutoff effect similar to an opening in a shield will show more leakage as the frequency is increased.

RF leakage testing was performed from 50 MHz to 18 GHz with the following results:

Table 1: Comparison of Harbour’s LL, SB, and SS cables to MIL-C-17 constructions

Sample		Shield Configuration	RF Leakage
Number	Cable type		
1	M17/111-RG303	single, round wire silver plated copper braid	- 50 dB
2	M17/60-RG142	double, round wire silver plated copper braids	- 75 dB
3	LL142	silver plated copper strip braid round wire, silver plated copper braid	- 80 dB
4	SB142	silver plated copper strip braid aluminum kapton	- 90 dB
5	SS402	spiral wrapped, silver plated copper strip round wire, silver plated copper braid	-110 dB
6	SS405	spiral wrapped, silver plated copper strip round wire, silver plated copper braid	-110 dB
7	M17/133-RG405	solid copper tube	-110 dB

Results for the MIL-C-17 cables are consistent with previously reported results. Single and double braided shield configurations, even those with greater than 90% braid coverage, still exhibit the highest RF leakage at -50 dB and - 75 dB respectively.

LL and SB cables with composite stripbraid/round wire braid configurations exhibited lower RF leakage in the -80 dB to - 90 dB range.

Spiral strip shields (Harbour’s SS cables) further improve RF leakage to - 110 dB. The tightly applied strip most closely approximates the solid copper tube of semi-rigid cable showing leakage levels down in the noise floor of the test equipment.

Figure 3: Shielding effectiveness, a comparative analysis

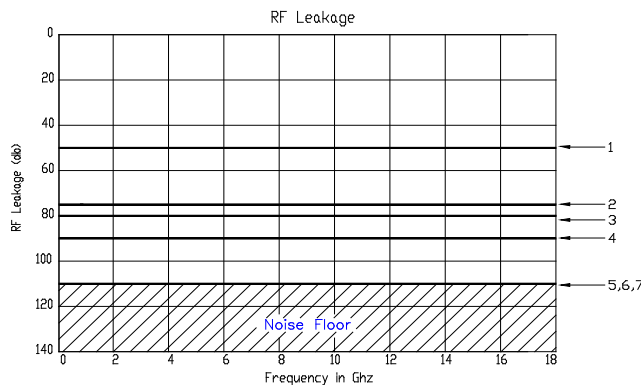

Sample	Shield configuration	RF Leakage
1	1 round braid (M17/111-RG303)	- 50 dB
2	2 round wire braids (M17/60-RG142)	- 75 dB
3	1 strip braid + 1 round braid (LL142)	- 80 dB
4	1 strip braid + tape inerlayer + 1 round wire braid (SB142)	- 90 dB
5	1 spiral wrapped strip + 1 round wire braid (SS402)	-110 dB
6	1 spiral wrapped strip + 1 round wire braid (SS402)	-110 dB
7	solid copper tube (M17/133-RG405)	-110 dB

Table 2: Special SS402 and SS405 testing

Sample		Bend radius of the sample	Minimum recommended bend radius	RF Leakage	Change
Number	Cable type				
5	SS402, straight	N/A	.82"	- 110 dB	
8	SS402, 360 loop	.52"	.82"	- 110 dB	+ 10 dB
6	SS405, straight	N/A	.52"	- 110 dB	
9	SS405, 360 loop	.52"	.52"	- 110 dB	-0-

Sample 8: An 8 inch test cable of SS402 with a 360° loop was bent into a tight .52" radius to fit inside the test cell. This bend radius exceeded the .82" minimum recommended bend radius for the cable (five times the .163" diameter). RF leakage was measured at - 100 dB. When the spiral strip shielded SS402 cable was tightly bent, the inner tape separated just enough to cause a + 10 dB change in shielding effectiveness.

Sample 9: An 8 inch test cable of SS405 with a 360° loop and was bent with a .52" radius, then inserted into the test cell. This bend radius was the minimum recommended bend radius of the cable (five times the .104" diameter). The RF leakage was measured at - 110 dB, the same as the straight length of the cable and the noise floor of the equipment.

The above tests show that bent lengths of Harbour's SS cables exhibit the same shielding effectiveness level as straight lengths, if the minimum bend radius is not exceeded.

***Using the shielding effectiveness test method as a design tool***

Harbour's RF leakage cell allows the convenient testing of many different cables at frequencies up to 18 GHz. It provides an effective, reliable and repeatable method not only for testing, but for the design of effective shield configurations. Physical characteristics of the braid configuration -- braid angles, picks per inch, number of carriers, braid coverage, tape widths, tape thickness, and percent overlap of metal tapes -- can be tested and modified for optimal shielding effectiveness.